



Product Specification

Name PACK Wall-Mounted Parts

Product Model C300

Date 2020-06-10

UZ		Client	
Drafted	Approved	Confirmed	Approved

Shenzhen UZ Energy Limited

Address: 15/F, Tower 3, Excellence City, No.128, Zhongkang Rd., Shenzhen, China

Tel: 86-755-83128098 **Mail:** marketing@uzenergy.com **Web:** <http://www.uzenergy.com>

 SHENZHEN UZ ENERGY LIMITED	Product Name	Product Number	C300
	PACK Wall-Mounted Parts	Effective Date	2020-06-10
		Version	V1.0

Content

1. Scope.....		3
2. Technical parameters.....		3
3. Holder Structure.....		3
4. Transportation and Storage.....		7
4.1 Transportation.....		7
4.2 Storage.....		7
5. Attention and Statements.....		7
5.1 Precautions.....		7
5.2 Declaration.....		7

 SHENZHEN UZ ENERGY LIMITED	Product Name	Product Number	C300
	PACK Wall-Mounted Parts	Effective Date	2020-06-10
		Version	V1.0

1. Scope

This document is a specification, as an input file for the design and development of the Parts, and as a standard for acceptance of Parts.

2. Technical parameters

Key parameters are listed below

Front Cover:

NO.	Key Item	Specification	Remark
3.1	Material	SGCC Steel, 1.2mm Thickness	
3.2	Surface	Paint, White ,Fine sand grain	
3.3	Weight	~1.5Kg	Refer to actual measurements
3.4	Dimension	W: 443mm D: 48.2mm H: 548mm	

Side Hanger:

NO.	Key Item	Specification	Remark
3.1	Material	SGCC Steel, 1.5mm Thickness	
3.2	Surface	Paint, black (color No. RAL9011)	
3.3	Weight	~1.2Kg	Refer to actual measurements
3.4	Dimension	W: 91mm D: 46.5mm H: 510mm	

Base:

NO.	Key Item	Specification	Remark
3.1	Material	SGCC Steel, 1.5mm Thickness	
3.2	Surface	Paint, black (color No. RAL9011)	
3.3	Weight	~1.5Kg	Refer to actual measurements
3.4	Dimension	W: 368mm D: 17mm H: 320mm	

 SHENZHEN UZ ENERGY LIMITED	Product Name	Product Number	C300
	PACK Wall-Mounted Parts	Effective Date	2020-06-10
		Version	V1.0

3. Structure

The appearance design of the Front Cover is as follows:



Figure 1、Front Cover Appearance Diagram

The appearance design of the Side hangers is as follows:



Figure 2、Side Hangers Appearance Diagram(2pcs/set)

When Pack Wall-Mounted , The front-panel and side hanger are fixed with M4 screws with the battery box, Then fix the back panel on the wall with explosive screws, hang the battery box on the back panel through

 SHENZHEN UZ ENERGY LIMITED	Product Name	Product Number	C300
	PACK Wall-Mounted Parts	Effective Date	2020-06-10
		Version	V1.0

side hanger, and fix the back panel with M6 screws on both sides., The appearance design as follows:

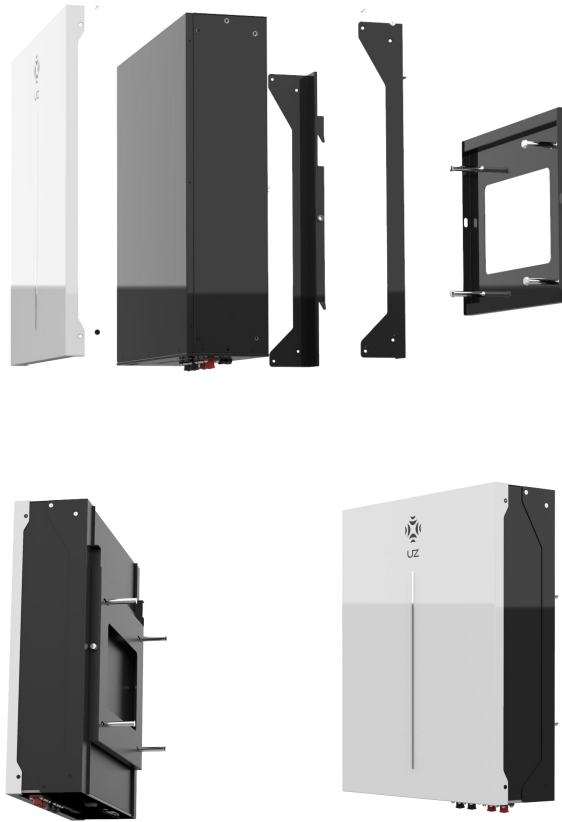
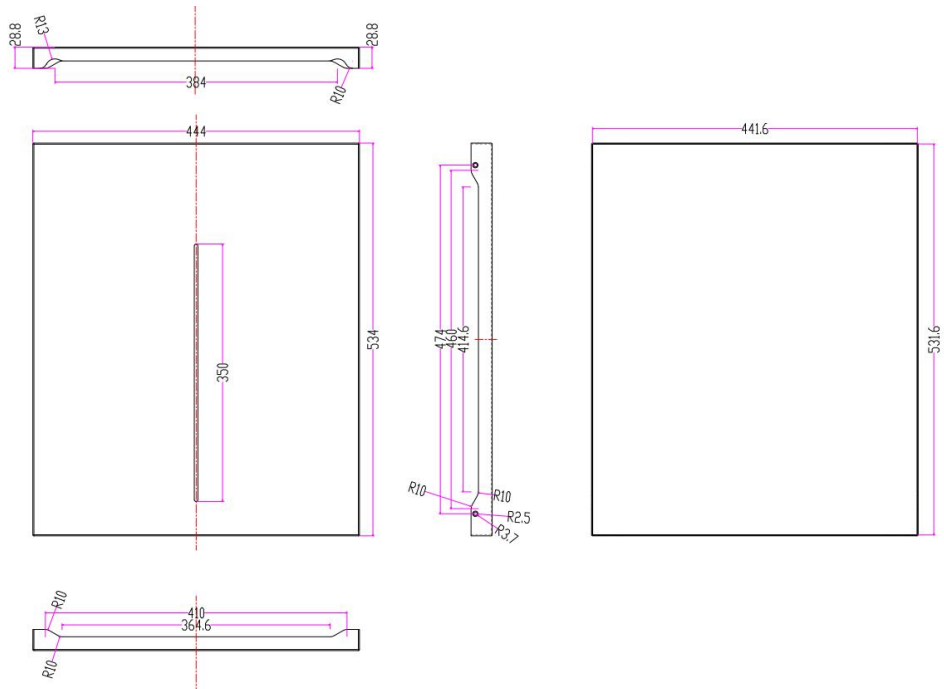

Figure 3、 The vertical installation Parts Appearance Diagram

The Wall-Mounted installation Parts Size Chart:



 SHENZHEN UZ ENERGY LIMITED	Product Name	Product Number	C300
	PACK Wall-Mounted Parts	Effective Date	2020-06-10
		Version	V1.0

Figure 4、Front Cover Size Chart

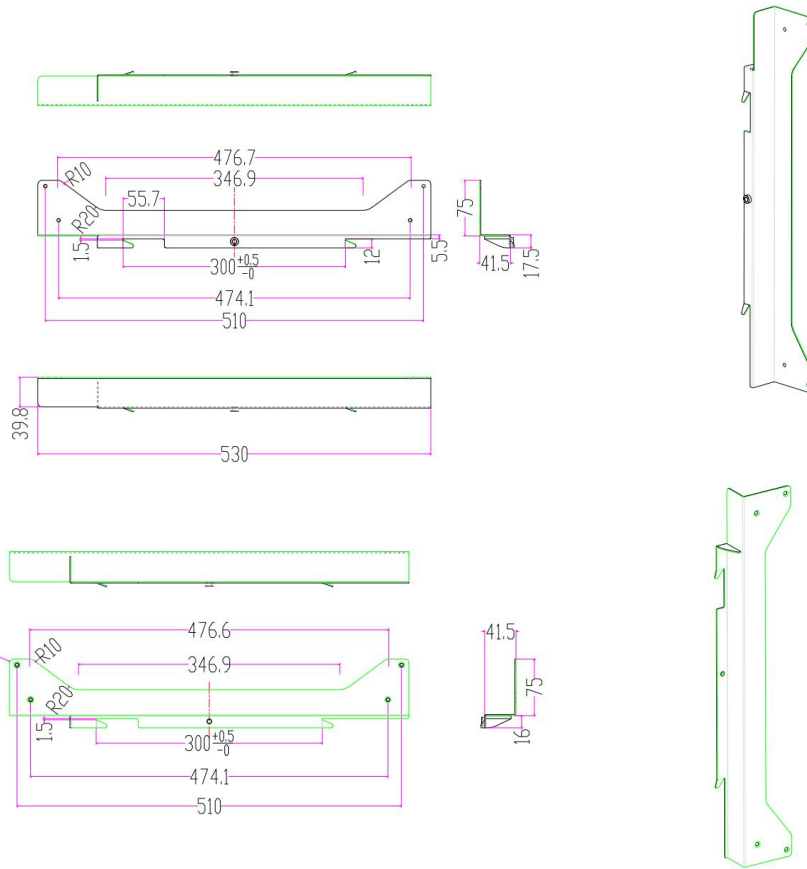

Figure 5、Hanger Size Chart

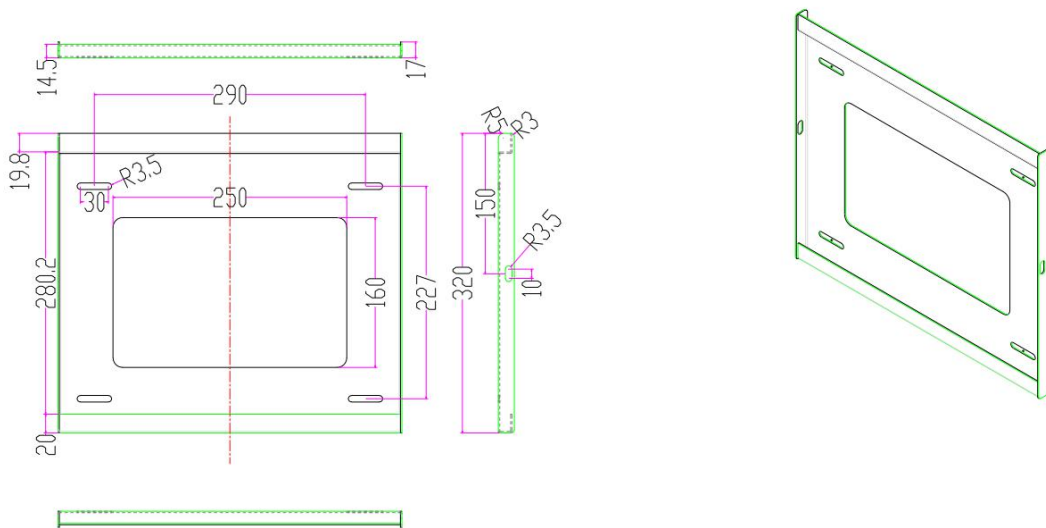



Figure 6、Base Size Chart

 SHENZHEN UZ ENERGY LIMITED	Product Name	Product Number	C300
	PACK Wall-Mounted Parts	Effective Date	2020-06-10
		Version	V1.0

4. Transportation and Storage

4.1 Transportation

During transportation, it should be protected from severe vibration, shock, sun and rain, and should not be inverted to ensure that short circuits will not occur. During the loading and unloading process, it should be handled gently to prevent falling, rolling, heavy pressure and inverted.

4.2 Storage

Product storage requirements are as follows:

- Product storage place should be rain, moisture, sun protection measures.

5. Attention and Statements

5.1 Precautions

This product must comply with the operating instructions, and any installation, maintenance and use of this product must strictly comply with the relevant safety regulations.

- The installation and maintenance of the products must be operated by professional technicians, and the relevant safety regulations must be strictly observed

5.2 Declaration

The right to interpret this specification belongs to Shenzhen UZ Energy Limited.